



ENGLISH

Electronic freeze protection alarm with warming function, double relays and digital display.

- CFA-24V Freeze protection alarm 24V AC
- CFA-230V Freeze protection alarm 230V AC



WARNING: IMPORTANT INFORMATION CONCERNING ELECTRICAL SAFETY AND ENVIRONMENT

This product may contain dangerous voltage. The product's housing is not meant to be removed. At a supply voltage of 230V AC the product must be powered via a nearby mains switch labelled "Mains Switch for CFA freeze protection alarm". The product's relay switch can be powered with 230V. The power must be switched off during maintenance. The product is intended for indoor use only. The product must not be subjected to liquid or moisture. The product's exterior can be cleaned using a damp cloth. The product is intended for mounting on a DIN rail / Norm enclosure in a protected space.

INDEX

1. Technical Data
2. Function
3. Use
4. Installation
5. Maintenance
6. Buttons and menu system
7. Selection of temperature sensor type – factory setting: Pt1000
8. Setting the setpoint
9. Resetting the alarm
10. Fine-adjustment of the temperature measurement
11. Display example
12. Error codes and temperature / Ohms table
13. Figures
14. Connection examples for CFA-24V and CFA-230V
15. Menu system – monitoring / shortcut menu

1. TECHNICAL DATA

- Supply voltage**
- CFA-24V:** 24V AC ±10%,
- CFA-230V:** 230V AC ±10% 50-60 Hz
- Relay outputs:** 250V ~ 5 A resistive loading, potential-free changeover
- Power consumption:** 4W
- Output signal:** 0-10V or 10-0V
- Temperature range**
- Alarm temperature:** 0 to 20°C
- Warming function:** 5 to 50°C
- Ambient temp.:** 0 to +40°C
- Selectable temperature sensor:** Pt1000 (factory setting), NTC (Calectro type: 22/33/44/55/99), Pt100, Ni1000, and PTC (Calectro type: 95)
- Mounting:** DIN rail, Norm enclosure
- Dimensions WxHxD:** 52.5 x 86 x 59 mm
- Weight:** 240 gram
- Protection class:** IP20

2. FUNCTION

CFA is connected to a temperature sensor that measures the water temperature in the heating coil. The water temperature in the heating coil is normally regulated by another regulator/DUC with the control signal (0-10 or 10-0V) connected via CFA to the control valve. If the water temperature in the coil drops without any response from the regulator / DUC, CFA starts regulating the control valve.

When the water temperature in the coil drops below the pre-set alarm temperature, both relay outlets fall (normally activated).

Daytime mode

During daytime the control signal regulates with a proportional band of 4°C. The control signal begins regulating when the temperature drops to the pre-set alarm temperature plus one degree plus the proportional band.

Example 1: Alarm temperature = 5°C: The control signal begins regulating at 10°C (5+1+4).

Example 2: Alarm temperature = 5°C: At or under 6°C the control signal is 100%.

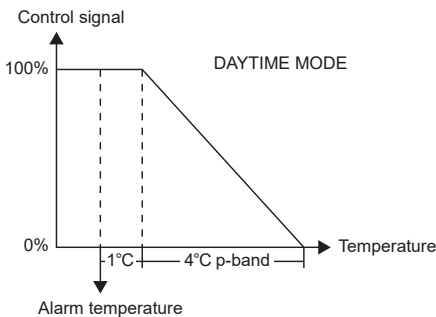

Daytime mode is activated by a short circuit between terminals 9 and 12. During daytime mode, D4 is shown in the top right-hand corner of the display and DI (under °C) is lit to indicate that the digital input (DI) is short-circuited.

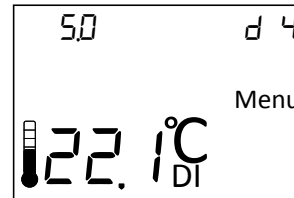

Night mode / warming function

During night mode (warming function) the water temperature in the heating coil is regulated by a setpoint that is adjustable between 5 and 50° (proportional band: 10°C).

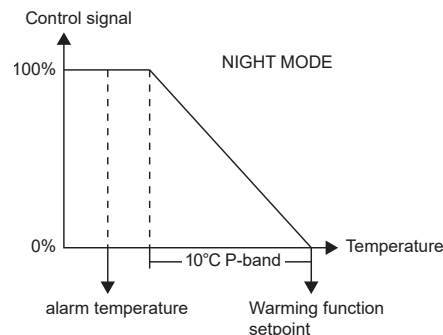

Night mode is activated by cutting any jumpers between terminals 9 and 12.

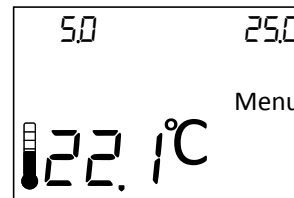

Self-test

During start-up and the replacement of temperature sensors, CFA performs a self-test. Three lines begin to blink at the bottom of the display. The current temperature shows up here on completion. Interruption on the temperature sensor circuit shows up as Er0 on the display, and Er1 for short circuit. Upon interruption or short circuit, the alarm relays fall and the control signal goes to 100%.

3. USE

CFA is an electronic freeze protection alarm with a digital display that is used to monitor frost in air heating systems that use water as the heat carrier.

4. INSTALLATION

CFA is mounted on a DIN rail and is suited to Norm enclosures.

5. MAINTENANCE

CFA requires no maintenance.

6. BUTTONS AND MENU SYSTEM

▲ = Step up in the menu / increase value - Keep the button depressed and the setpoint counts up rapidly.

▼ = Step down in the menu / decrease value - Keep the button depressed and the setpoint counts down rapidly.

↵ = Is a multifunction button, the current status* of which is shown on the display next to the button.

* Middle button functions:

- Exit Menu = Exit the menu / Save setting
- Menu = Enter the menu or select application
- Enter = Confirm setting
- Reset = Resets the relay after an alarm.

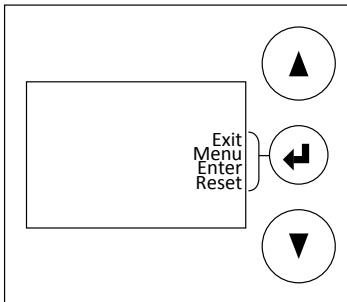

The menu system comprises of the following sub-menus:

1. Selection of temperature sensor
2. Fine-adjustment of the temperature measurement
4. Selection of output signal: 0-10 or 10-0V
5. Exit the menu system

7. SELECTION OF TEMPERATURE SENSOR

CFA can be connected to a range of temperature sensors: Pt100, Pt1000, Ni1000 plus Calectros NTC and PTC sensors in the ETF series. Pt1000 is a factory set sensor.

2. Press the Menu button (↵) to enter the menu system
3. The current type of temperature sensor is shown
4. Press Menu-Enter to change the temperature sensor type
5. The current sensor type begins to blink and you can now use the arrow buttons to select another sensor type. Press Enter to confirm your selection.
6. Use the arrow keys and confirm Exit-Menu to exit

8. SETTING THE ALARM TEMPERATURE AND HEAT RETENSION SETPOINT

To change the alarm temperature, press ▲ or ▼ to the desired value. The alarm temperature, which is shown in the top left-hand corner, blinks during setting. Press Enter to confirm (↵).

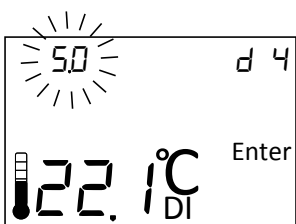

The setpoint for warming function (night mode), which is shown in the display's top right-hand corner, now begins to blink. Use ▲ to ▼ change to desired value and press Enter to confirm (↵). Ready!

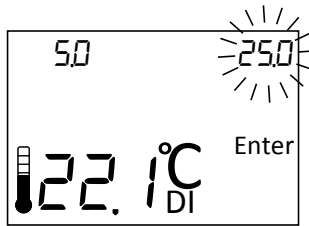

These settings can also be changed during an alarm.

9. RESETTING THE ALARM

When the alarm triggers, the relays remain in alarm mode until the reset button is pressed.

Freeze alarm in daytime mode

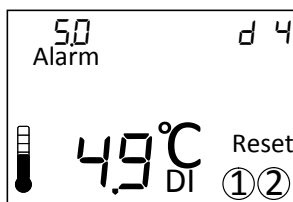

Freeze alarm in night mode

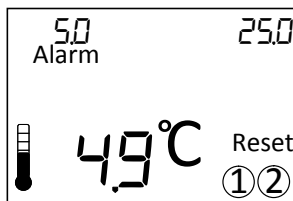

If the alarm mode returns to normal temperature when the Reset button is pressed, the relays are reset and the middle button returns to the Menu function.

If the alarm is still triggered after the Reset button is pressed, the relays have not been reset and Alarm and Reset blink three times. The middle button then returns to the Menu function for 20 seconds to allow settings to be changed in the menu system before returning to Reset.

Reset depressed in alarm mode (daytime mode)

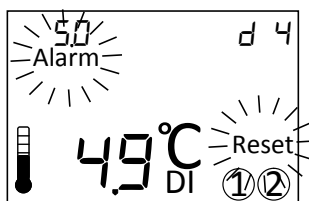

Reset depressed in alarm mode (night mode)

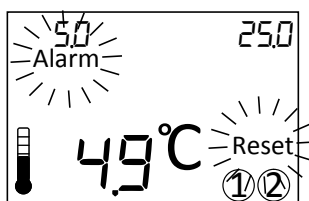

The alarm temperature and warming function setpoint can always be adjusted, even during alarm mode. See 8.

10. FINE ADJUSTMENT OF THE TEMPERATURE MEASUREMENT

The temperature measurement in CFA can be adjusted if necessary. Range: -3°C to +3°C in steps of 0.1°C.

1. Press the Menu button (↵) to access the menu system
2. Press the arrow key until 'Adj' shows on the display
3. Press Menu-Enter to adjust
4. The current compensation and temperature starts to blink and you can now adjust the compensation using the arrow keys. Press Enter to confirm your selection (↵).
5. Use the arrow keys and confirm Exit-Menu to exit

11. DISPLAY EXAMPLE

The below example shows CFA in daytime mode. The freeze alarm has triggered.

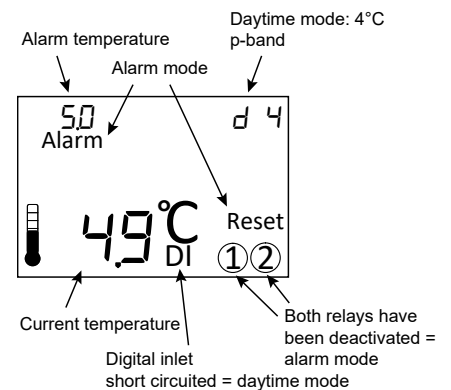

The below example shows CFA in night mode / warming function. The freeze alarm has triggered.

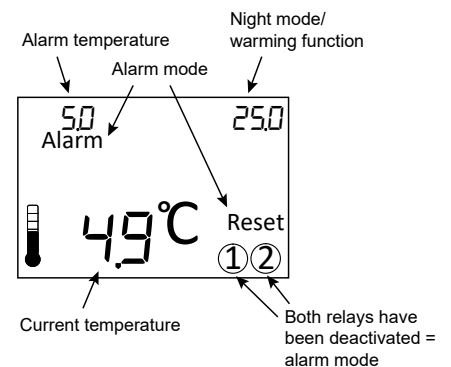

12. ERROR CODES

CFA monitors the temperature sensor so that a short circuit or interruption on the sensor circuit triggers the alarm and sets the control signal at 100%.

- Er0 Interruption on the sensor input
- Er1 Short circuit on the sensor input
- Er2 Temperature sensor out of range

Temperature / Ohm table

Sensor type	Temperature	Ohm
Pt1000	0°C	1000
	20°C	1078
	40°C	1156
Pt 100	0°C	100
	20°C	107.8
	40°C	115.6
Ni1000	0°C	1000
	20°C	1090.7
	40°C	1185.7
NTC (Calectro type 22/33/44/55/99)	0°C	37942
	20°C	14871
	40°C	6539
PTC (Calectro type 95)	0°C	1631
	20°C	1915
	40°C	2226

13. FIGURES

FIG. 1

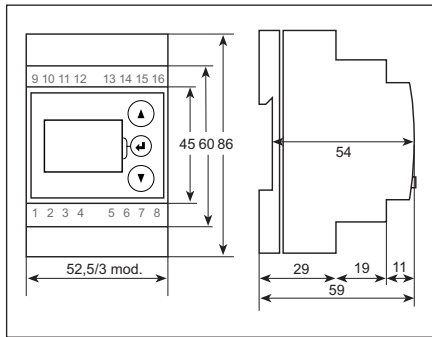

FIG. 2 (CFA-24V)

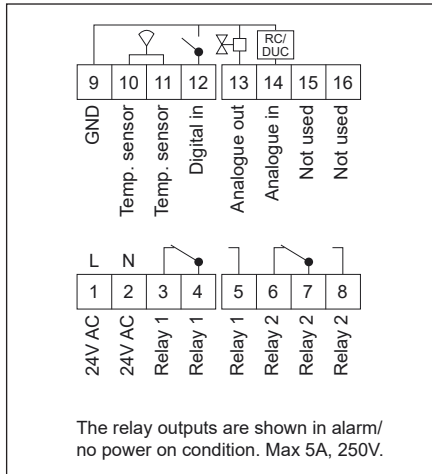
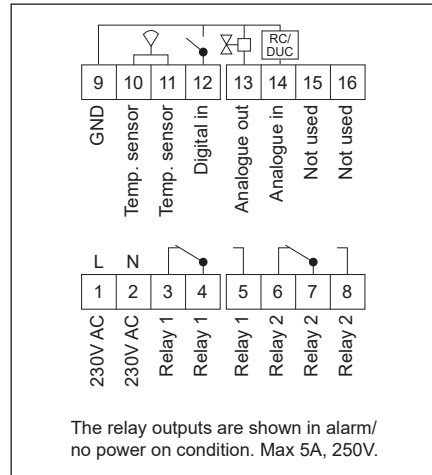
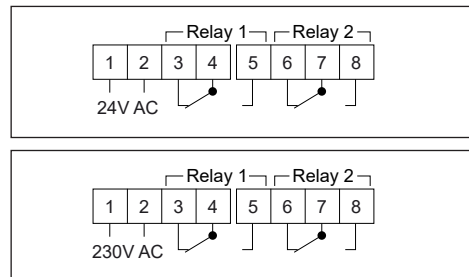

FIG. 3 (CFA-230V)



14. CONNECTION EXAMPLE FOR CFA-24V AND CFA-230V

The relays are shown in alarm/ no power on condition.



15. MENU SYSTEM – MONITORING

Press Menu  to access the Menu System.
 Navigate between the submenus using the arrow keys and select sub-menu with Menu-Enter.

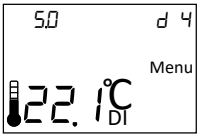

Select the type of temperature sensor. Navigate between the different types and confirm with Enter.

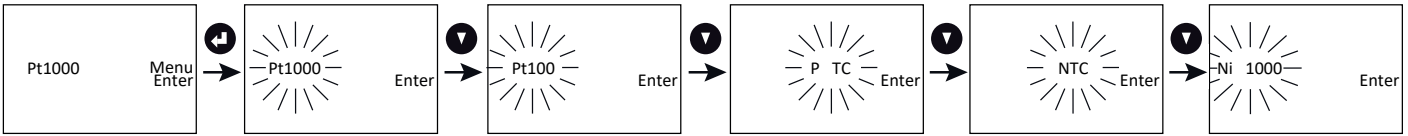

If necessary the temperature measurement may be fine-tuned (-3.0 to +3.0°C). Confirm with Enter.

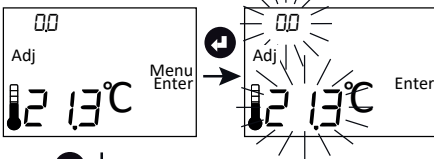

Select the desired output signal: 0-10V or 10-0V. Confirm with Enter.

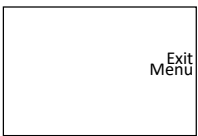

Save settings and return to the normal display position through Exit-Menu.

